



For Earth, For Life
Kubota

U

KUBOTA COMPACT EXCAVATOR U27-4

Extra compact and tough enough to tackle the most demanding tasks in tight spaces with ease.



Kubota

©2019 Kubota Corporation

Kubota Australia Pty Ltd

25-29 Permas Way, Truganina VIC, 3029 Australia
Freecall: 1800-334-653
Email: sales@kubota.com.au

Web Site: <http://www.kubota.com.au>

Kubota New Zealand Limited

Freecall: 0800-582-682
Email: sales@kubota.com.au

Web Site: <http://www.kubota.co.nz>

**Kubota
Genuine Parts**
for maximum
performance,
durability and
safety



*This information is sourced from overseas and may not necessarily apply locally. It is essential that you confirm specifications and other information with your local Kubota dealer.

SUPERIOR PERFORMANCE

The U27-4 is designed to handle the challenging jobs that are way out of reach for bigger excavators. The zero-tail swing lets you travel through and turn smoothly in tight spaces with ease. And features like a powerful digging force and easy simultaneous operation of four functions and more, offer performance you can truly rely on.

Kubota original engine

The U27-4 is powered by Kubota's tough and reliable engine. Engineered with the power to maximise digging and lifting performance, it also delivers minimised noise and vibration.



Powerful digging force

The U27-4 delivers an impressive bucket digging force. Its powerful and well-balanced arm and bucket allow the operator to dig faster, deeper (2820 mm) and more efficiently even in the toughest conditions. It offers powerful workability and excellent stability without the need of additional weights that are often required by other zero-tail swing excavators.

Simultaneous operation of four functions

When the simultaneous operation of the boom, arm, bucket, and swivel are required, two variable pumps will distribute an accurate amount of oil flow to each actuator according to the lever stroke. This process enables continuous high performance digging and dozing.

Third-line hydraulic return

When working with one-way hydraulic attachments, such as breaker or brush cutter, the standard third-line hydraulic return system allows oil to flow directly back to the tank without running through the control valves. This contributes to less oil contamination, reduced back pressure, and greater oil flow efficiency.

Zero-tail swing

With zero-tail swing, even the tightest spaces become efficient work places. The tail's minimal protrusion outside the track width lets you turn throughout its 360-degree turning radius with complete confidence and safety and fewer accidents with things around you. It also maintains better balance over conventional zero-tail swing excavators and faster operation, making this mini-excavator ideal for work in congested urban areas and inside buildings.



Standard AUX1 & AUX2 and proportional flow control of auxiliary circuit

U27-4 is available with a standard AUX1 and AUX2. It enables to further increase machine versatility. The convenient thumb-operated switch on the lever allows easy proportional flow control of the auxiliary circuit.



Left control lever

Right control lever

Adjustable Maximum oil flow control AUX circuit 1 & 2

The AUX oil flow adjust dial is conveniently located on the top of meter panel.



Auto-shift

The auto-shift automatically shifts travel speed from high to low, depending on traction and terrain, allowing smoother operation when dozing and turning.

Rocker switch for AUX2 and Swing boom

The round switch on the left lever permits easy switching between AUX2 and the Swing function. Also it provides more foot space for greater operator comfort.



DELUXE INTERIOR

The luxurious interior features a wider entrance, greater legroom and a deluxe seat. Operability is greatly enhanced with more easy-to-use features than ever before.



TPSS

The Two-Pattern Selection System positioned under the seat allows the operator to shift control styles conveniently while seated. A simple turn of a switch is all it takes to select between the ISO pattern and the SAE backhoe pattern.

New Digital Panel

The new user-friendly digital panel puts convenience at your fingertips. Positioned to the front right corner of the operator for better visibility and accessibility, it features easy one-touch button operation to view the time, hour meter and tachometer. Warning lamps with code numbers on the display will alert you in case of emergencies such as overheating, hydraulic problems or low battery.



A. Flat Foot Space

The flat foot space enhances comfort by providing ample leg room to reduce fatigue even during long hours of operation.

B. 2-speed Travel Switch

By placing the 2-speed travel switch on the dozer lever, dozing operations can be done faster and easier.



C. Cup Holder

With the convenience of a bigger cup holder, you can quench your thirst and work longer without leaving your seat.

D. Wrist Rest

A thoughtfully designed wrist rest enhances operation and reduces operator fatigue.

E. Suspension Seat

Designed for better fit and comfort even for long hours of work, Kubota's high-back suspension seat minimises strain and operator fatigue by accommodating your individual posture and weight. A seat belt is fitted as standard.

1. Fuel Level Gauge

2. Water Temperature Gauge

3. Warning Lamps

(Engine oil pressure, Battery charge, Coolant temperature)

4. LCD Display (Time, Hour, rpm)

Time

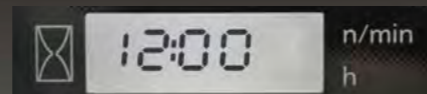

Hour Meter

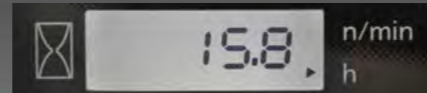

Tachometer

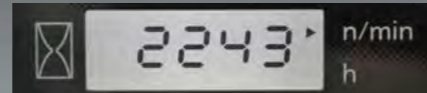

MAINTENANCE & SAFETY

With the U27-4, you can work with total confidence thanks to its sturdy and durable ROPS/OPG for maximum operator safety and accident avoidance features such as work lights. Furthermore, the engine is ergonomically organised with easy access to the radiator and engine oil cooler to make routine maintenance and inspections a breeze.

ROPS/OPG (top guard, level I) canopy and cabin

The ROPS/OPG (Top Guard, Level I) canopy provides protection in the event of accidental rollovers and falling objects.



A. Battery

B. Radiator

C. Oil cooler

D. Air cleaner

E. Reserve tank

F. Fuel filter

G. Water separator



Travel lock system

The travel lock system locks the tracks to prevent inadvertent movement of the machine. This keeps the excavator secure during transport or while parked on slopes.

Swivel negative brake

The swivel negative brake automatically locks the swivel function in its current position. This prevents unexpected machine movement. It's particularly useful during work on slopes or when towing the excavator between worksites.

Protected cylinder hoses

The cylinder hoses for arm and bucket are located inside the boom to protect the hoses from damage.

U27-4 OPTIONS

STANDARD EQUIPMENT

Safety system

- Travel lock system
- Fully locked hydraulic system
- Swivel motor with disc brake
- Travel alarm

- 12V power outlet
- Two pattern selection system
- Cup holder
- Horn

Working equipment

- 2 working lights on canopy and 1 light on the boom
- Auxiliary hydraulic circuit 1 and 2 with proportional control and oil flow adjust dial

Engine/Fuel system

- KUBOTA original engine
- Double-element air cleaner
- Fuel level indication buzzer
- Electric fuel feeding pump

Undercarriage

- 2-speed travel
- Double flange track roller
- Short pitched rubber crawler
- Auto down shift

Operator's space

- Weight-adjustable suspension seat (PVC seat)
- Retractable seat belt
- Hydraulic pilot control levers with wrist rests
- Digital panel with diagnosis function
- ROPS/OPG (Top Guard Level I) canopy
- Switch and harness for beacon light

Hydraulic system

- Variable displacement pump
- Auxiliary hydraulic circuit piping to the arm's end

- AUX 1 & 2 proportional flow control of auxiliary circuit
- AUX oil flow adjust dial
- Third line hydraulic direct return for AUX 1
- Straight travel circuit
- Hydraulic pressure checking ports

Others

- Tool storage space

OPTIONAL EQUIPMENT

- Safety valve for boom and arm
- Battery isolator support kit
- Foot pedal

WORKING RANGE

Model		U27-4		
A	Max. digging height	mm	4370	
B	Max. dumping height	mm	3100	
C	Max. digging depth	mm	2820	
D	Max. vertical digging depth	mm	2580	
E	Max. digging radius at ground	mm	4630	
F	Max. digging radius	mm	4740	
G	Min. turning radius	W/O swing	mm	1970
		W swing	mm	1539
H	Min. tail turning radius	mm	790	

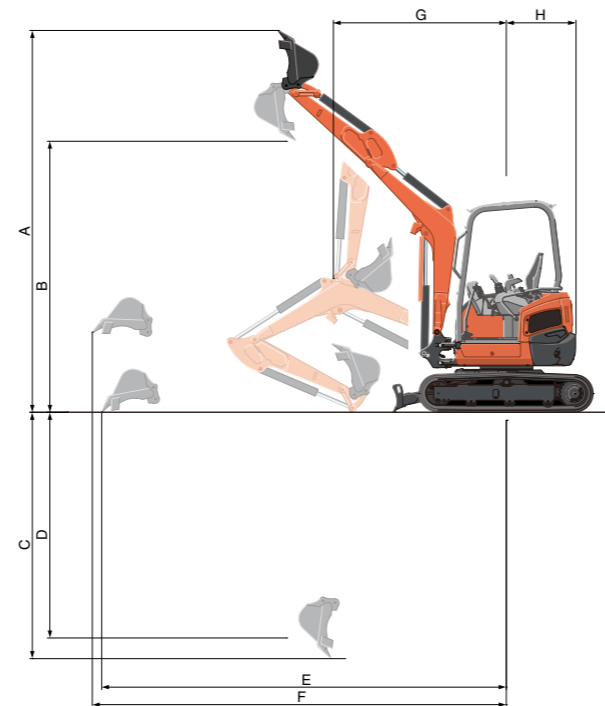

LIFTING CAPACITY

LIFT POINT HEIGHT (m)	LIFTING CAPACITY OVER-FRONT BLADE DOWN unit = kg			LIFTING CAPACITY OVER-SIDE unit = kg		
	LIFT POINT RADIUS (m)			LIFT POINT RADIUS (m)		
	2.5	3.5	MAX	2.5	3.5	MAX
2.5	—	400	—	—	300	—
1.5	560	440	420	480	290	230
0.5	800	510	440	440	280	230
GL	850	530	—	440	270	—

Machine with canopy and rubber crawler, without bucket

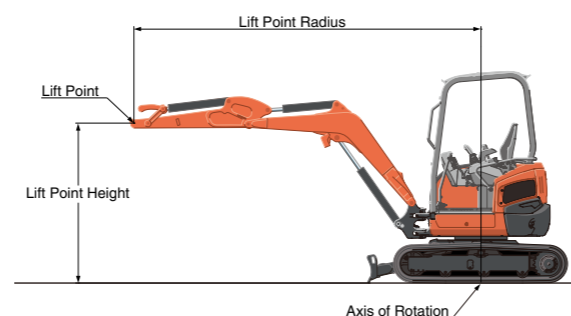

SPECIFICATIONS

Model		U27	
Type of ROPS / FOPS		Canopy	
Type of tracks		Rubber	
Engine	Model	Kubota D1105-BH	
	Output (SAE J1995 gross)	HP (kW)/rpm	20.9 (15.6) / 2400
	Output (SAE J1349 net)	HP (kW)/rpm	20.0 (14.9) / 2400
	Displacement	cc	1123
Dimensions	Overall length	mm	4100
	Overall height	mm	2420
	Overall width	mm	1500
	Min. ground clearance	mm	307
Hydraulic system	Pump capacity	ℓ/min.	28.8 variable × 2 / 19.2 gear × 1
	Auxiliary hydraulic flow	AUX1 / AUX2 ℓ/min.	48.0 / 19.2
	Max. breakout force	Bucket / Arm kgf	2645 / 1260
Drive system	Travel speed	Low / High km/h	2.6 / 4.3
	Max. traction force	kgf	3069
	Tumbler distance	mm	1560
	Crawler length	mm	1990
	Shoe width	mm	300
	Ground contact pressure	kPa (kgf/cm ²)	22.9 (0.23)
Swing system	Unit swing speed	rpm	9.9
	Boom swing angle	Left / Right degree	75 / 55
Blade	Dimensions	Width / Height mm	1500 / 300
	Max. lift above ground	mm	360
	Max. drop below ground	mm	320
Hydraulic oil (reservoir/system)		ℓ	22 / 37
Fuel reservoir		ℓ	33
Operating weight (Including operator's weight @ 75 kgs)		kgs	2570

The company reserves the right to change the above specifications without notice. This brochure is for descriptive purposes only. Please contact your local Kubota dealer for warranty information. For your safety, Kubota strongly recommends the use of a Rollover Protective structure (ROPS) and seat belt in almost all applications.

DIMENSIONS

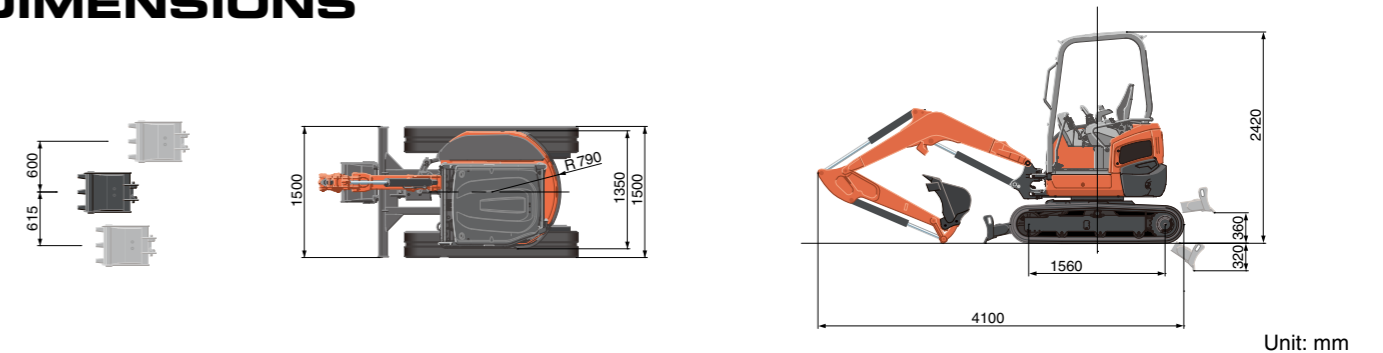

Unit: mm